

HELENSBURGH & DISTRICT BRANCH Christmas Dance 2024

CARDROSS JIG (2 facing 2 Round Room)

**THE FALLS OF ROGIE** **8x32 R**

$X_R$ 1	$X_R$ 2 1 3 2 1 3		
	$T_{R1\frac{1}{4}}$ 1 2 3 Chase		

Jean Attwood, Alexander Dances Book 1

3C/4C longwise set.

**INDIAN RIVER STRATHSPEY** **3x32 S**

	<b>RA</b> 1 2 3	<b>LA</b> 1 2 3	$S$ 2 3 1
	$RL$ 1 3	$RL$ 1 2	$RL$ to 3 1 2

George Senyk, <http://www.strathspey.org/lists/strathspey%40strathspey.org/m/23939/>

3C/3C triangular set.

**FAREWELL TO BALFOUR ROAD** **96 J**  
5 couples, 2C start on bar 17

1 2 	1 2 <b>S &amp; LINK</b>	1 3 <b>S &amp; LINK</b>	1 4 5 
	$S$ R	$S$ L	1x

Andrew Buxton, 2015, RSCDS Book 52.7

5C/5C longwise set.

**THE CUCKOO CLOCK** **8x32 R**

	1 2 DOUBLE FIGURE OF EIGHT	1 2 3 $X$ 1 $S$ $X_R$	$T_R$ 3x 1x 2x	<b>S &amp; LINK</b> 3x 1x 2x	
--	-------------------------------	--------------------------	----------------	------------------------------	--

Ian Barbour, 1991, Dance and Celebration

3C/4C longwise set

**THE SPIRIT OF THE DANCE** **8x32 S**

Tourbillon 1 2 $T_{B\frac{1}{2}}$		$S$ 1 1 2 2	$X_R$ 2x 1x
1 bar	1 bar	1 bar	1 bar
3 Couple RL 2 1x 3	$X_R$ 2 1 3	$X_L$ 1 2 2	$T_{B\frac{1}{2}}$ 1x
$X_R$ 2 1 3	$X_R$ 3 3 1	$X_L$ 1 2 2	$X_R$ 3 3 1

Irene Paterson, 1998, TAC 50th Anniversary Collection

3C/4C longwise set.

**RAY MILBOURNE** **4x32 R**  
2C & 4C cross on 2nd chord

$X_R$ 1 $X_R$ 1		$RL$ 1 4x	

Derek Haynes, 1976, Carnforth Collection 1

4C/4C longwise set.

**HOOPER'S JIG** **8x32 J**

ALL 1x 3 $\ast$ $\updownarrow$ 1 <b>RA</b>	ALL 1 2 $\ast$ $\updownarrow$ 1 <b>LA</b>	$X_R$ 1 2 3 $X_R$ 1 2 3	$X_R$ 3 2 1 $X_L$ 3 2 1
		$X_R$ 3 2 1	$RL$ 2 1

RSCDS MMM (34), RSCDS Thirty Popular Dances Vol 2

3C/4C longwise set.

**INTERVAL**

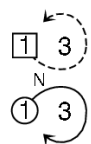
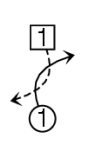
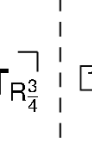
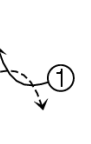
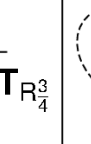
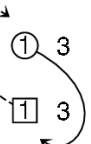
<b>HAUD YER WHEESHT!</b>						<b>8x32 J</b>
						

Anne Thorn, 2023

3C/4C longwise set.

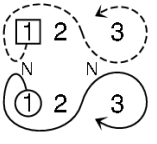
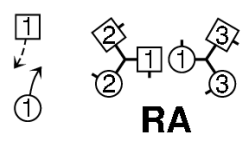
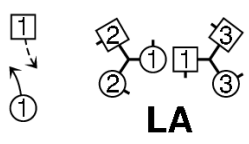
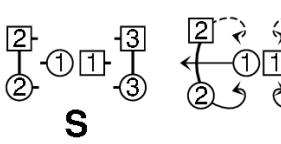
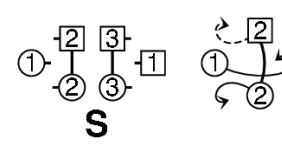
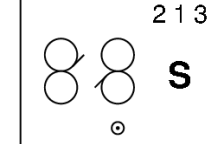
<b>TOAST TO THE MOUSIES</b>				<b>8x32 R</b>
				
				

Sara Gratiot, 2016, RSCDS Book 53

3C/4C longwise set.

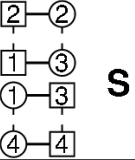
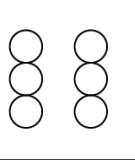
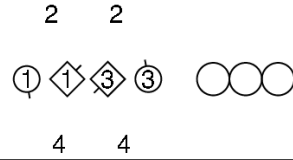
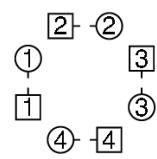
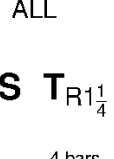
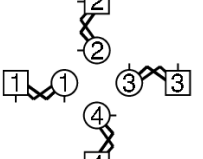
<b>MacDONALD OF KEPPOCH</b>				<b>2x32 S + 2x32 R</b>
				
				

Chris Ronald, 2013, RSCDS Book 49.11

4C/4C square set.

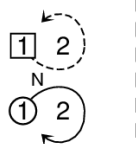
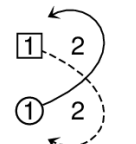
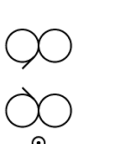
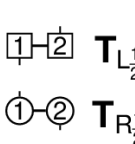
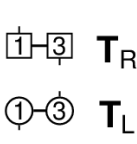
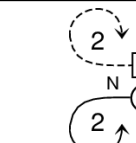
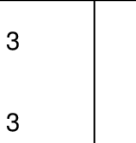
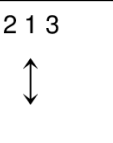
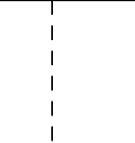
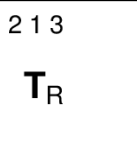
<b>THE SHETLAND SHEPHERDESS</b>					<b>8x32 J</b>
					
					

Ron Wallace, San Andreas Collection, RSCDS Graded Book 3.8

3C/4C longwise set.

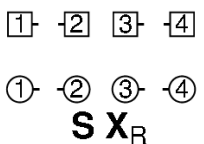
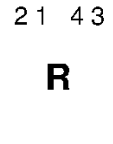
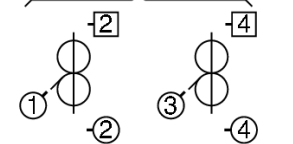
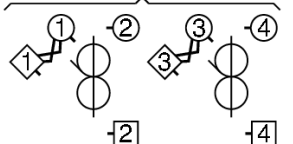
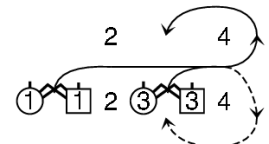
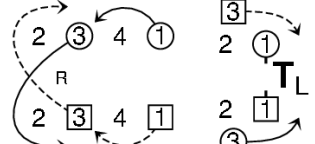
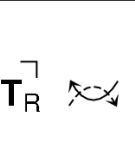
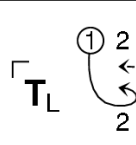
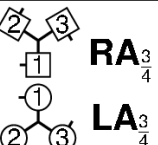
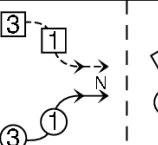
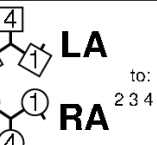
<b>THE EARL OF MANSFIELD</b>				<b>4x48 R</b>
				
				
				

John Drewry, 1980, RSCDS Leaflet 15, RSCDS Thirty Popular Dances Vol 2

4C/4C longwise set.

<b>THE FALKIRK LASS</b>				<b>8x32 S</b>
$T_R$ 1	$X_L$	 ALL $X_R$ 2 bars	 ALL $T_{R_4}^3$ 2 bars $X_R$	
Corners Pass & Turn			$T_B$	2 1 3 <b>6</b>

Elaine Brunken, RSCDS Book 53, Merse Collection, Moments in Time

3C/4C longwise set.

<b>ROARING JELLY</b>				<b>8x32 J</b>
$X_R$ 1		<b>6</b>		$X_R$

Hugh Foss, 1966, Glendarroch Sheet 6

3C/4C longwise set.

<b>A CHRISTMAS CEILIDH</b>					<b>8x40 R</b>
1 2 ↑↓	1 2 $T_R$	1 2 <b>A</b>	1 3 <b>RA</b>	1 3 <b>LA</b>	 2 1 3 <b>6</b>

Pam Perkins & Ann Gorman, 1992, New Forest SCDs

3C/4C longwise set.

**EXTRAS**

<b>THE MONTGOMERIES' RANT</b>					<b>8x32 R</b>
$X_R$ 1	$X_L$		$S$	$S$	$X_R$

Castle Menzies, 1749, RSCDS Book 10.1

3C/4C longwise set.

<b>THE ORCHARDS OF CO. ARMAGH</b>				<b>3x32 S</b>
	$S$ $T_{R_4}^3$			
		$S T_\diamond$		3 1 2 $T_B$

Jinty Anderson, RSCDS Book 53, Belfast Platinum Anniversary

3C/3C longwise set.

**Wishing You a Merry Christmas**

**And**

**A Happy, Healthy New Year**